



Very Well Connected™

INSTALLATION INSTRUCTIONS

Product

7160-0565-XX

T800 DOCKING STATION

Revision

REV. B

Form

INST-655

Printing Spec: PS-001

This instruction sheet is for the T800 docking station only. For instructions on features, set-up, and operation of the T800 computer, please refer to the manual provided by Getac with the computer.

This docking station is designed to be used with a variety of Gamber-Johnson mounting systems. Installation instructions for other Gamber-Johnson products are provided with each individual product.

This instruction sheet is for the following products:

Item No. 7160-0565-00 No RF
Item No. 7160-0565-03 Tri-RF

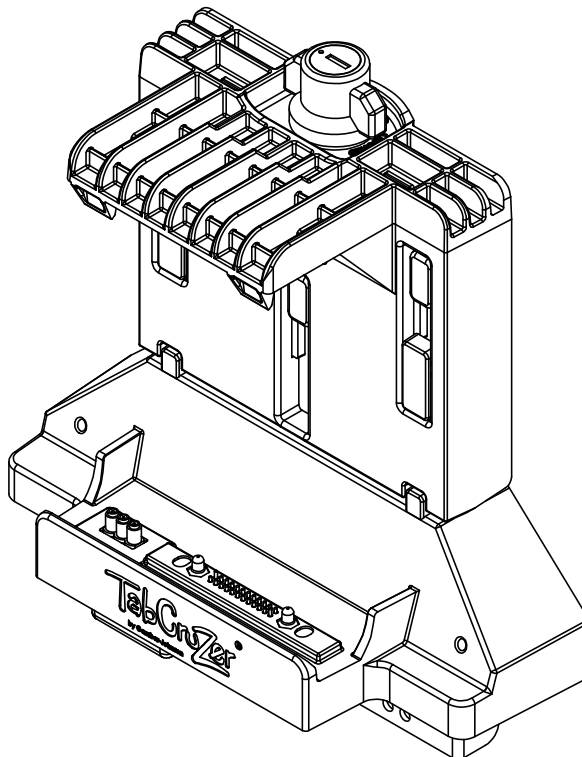

Product Mounting Disclaimer

Gamber-Johnson is not liable under any theory of contract or tort law for any loss, damage, personal injury, special, incidental or consequential damages for personal injury or other damage of any nature arising directly or indirectly as a result of the improper installation or use of its products in vehicle or any other application. In order to safely install and use Gamber-Johnson products full consideration of vehicle occupants, vehicle systems (i.e., the location of fuel lines, brakes lines, electrical, drive train or other systems), air-bags and other safety equipment is required. Gamber-Johnson specifically disclaims any responsibility for the improper use or installation of its products not consistent with the original vehicle manufactures specifications and recommendations, Gamber-Johnson product instruction sheets, or workmanship standards as endorsed through the Gamber-Johnson Certified Installer Program.

© Copyright 2015 Gamber-Johnson, LLC

If you need assistance or have questions, call Gamber-Johnson at 1-800-456-6868

PRE-INSTALLATION RECOMMENDATIONS

Conduct a "Bench Test"

Gamber-Johnson strongly advises a "bench test" be conducted to verify all electronic and software issues are resolved prior to installation:

1. Make sure the computer is operational by itself.
2. Insert computer into the docking station and verify that the computer is operating in the dock.
3. Interconnect entire assembly and verify start-up of all components, including other equipment (printers, modems, scanners, etc.)

Gamber-Johnson recommends positioning of all mounts and equipment in the vehicle prior to the actual install to verify that mounting locations are safe and practical.

IMPORTANT SAFETY INFORMATION FOR INSTALLERS

Safety is dependent on the proper installation and servicing of this docking station. It is important to read and follow all instructions before installing this product.

To properly install a Gamber-Johnson docking station you must have a good understanding of automotive electrical procedures and systems, along with proficiency in the installation and service of aftermarket vehicle equipment.

There are no adjustments required at any time of the electrical components within the docking station. **Opening the docking station will void the product warranty.**

During Installation:

DO NOT connect this docking station to the vehicle battery until:

1. All other electrical connections are made
2. Mounting of all components is complete
3. Verification that no shorts exist in the entire system

DO NOT install equipment or route wiring or cords in the deployment path of any air bag.

When drilling into the vehicle, DO make sure that both sides of the surface are clear of anything that could be damaged.

CAUTION: *If wiring is shorted to the frame, high current conductors can cause hazardous sparks resulting in electrical fires or flying molten metal.*

After installation:

Test the docking station to ensure that it is working properly.

File these instructions in a safe place and refer to them when performing maintenance or re-installing.

WARNING: *Failure to follow all safety precautions and instructions may result in property damage, serious injury, or death.*

T800 DOCKING STATION FEATURE IDENTIFICATION

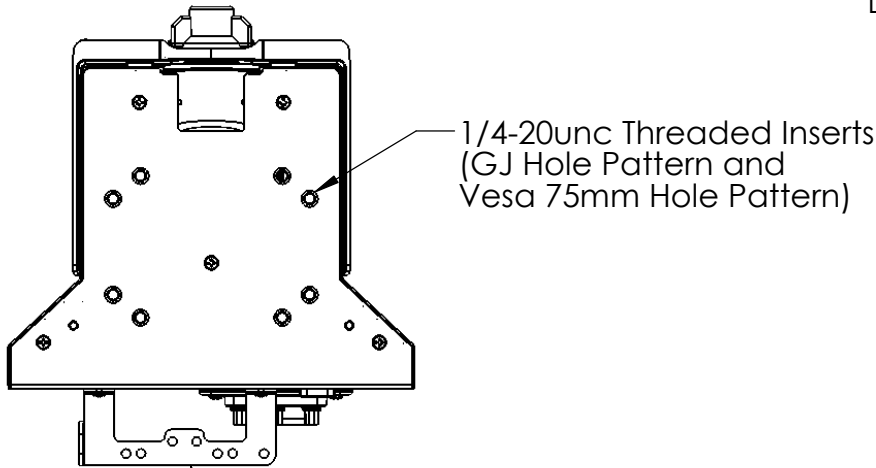
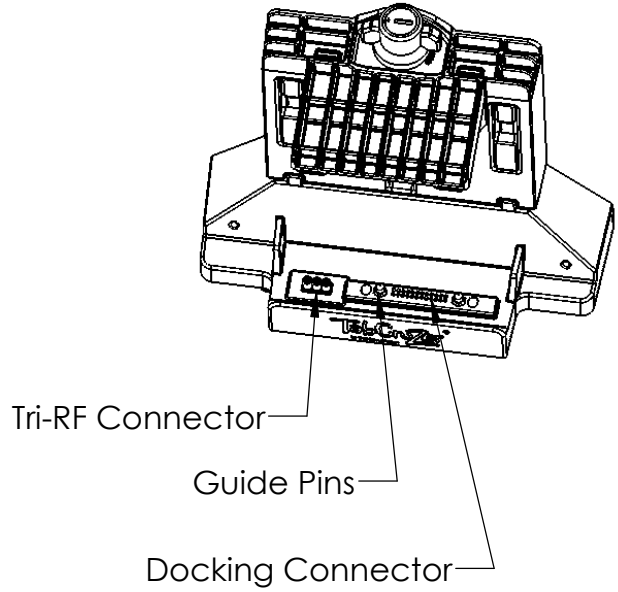
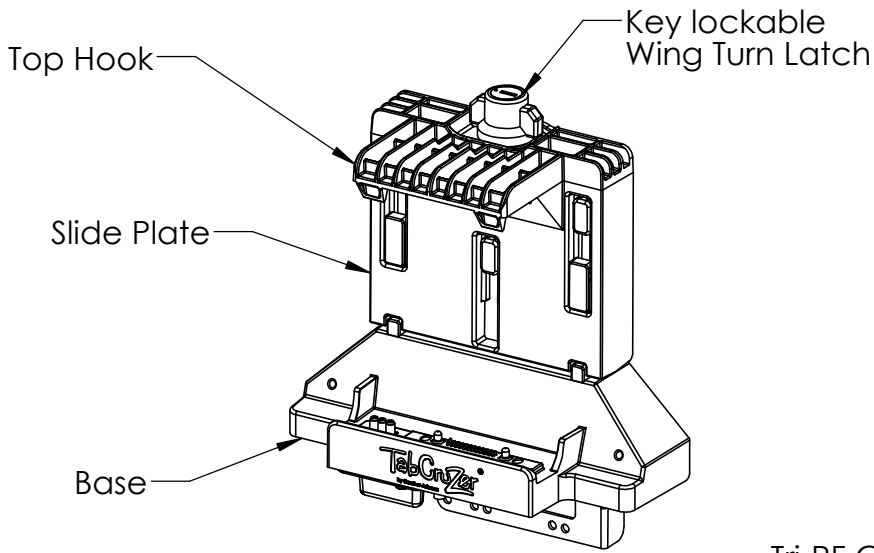

CABLE RESTRAINT BRACKET

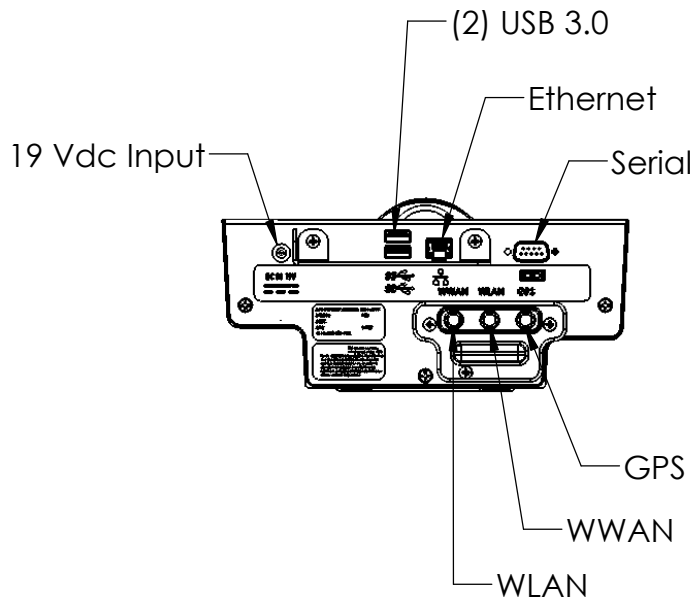

DOCKING AND UNDOCKING THE COMPUTER

1. With the slide plate in the open position, insert the bottom of the computer into the docking station. The guide pins on the dock will help to align the computer. Then rotate the top of the computer under the top hook until the computer is resting on the two supports sticking out behind the connector. (see Figures 1 & 2)

Figure 1



2. Push downward on the wing turn latch until the slide plate is holding the computer in place, then turn the latch to hold the slide plate in the downward position. (See Figure 3)

3. (Optional) The key lock can now be used for security purposes.

(Gamber-Johnson recommends locking the latch when used in high vibration applications to make sure the latch does not open)

Figure 2

Supports

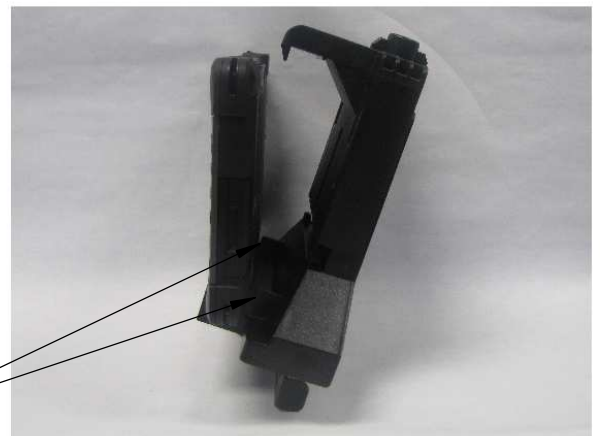

TO UNDOCK THE COMPUTER

1. Undock the computer by double clicking on the Getac Utilities icon on the desktop (OSDC). Click the **Docking** button to undock the computer.

Figure 3

2. Unlock if locked.

3. Rotate the wing turn latch 90 deg. The slide plate is spring loaded and should raise with your hand when you release the pressure on the slide plate.

4. Rotate the top of the computer out of the dock to remove.



Regulatory Certification Information

Regulatory Model #: 7160-0565

GJ Model #'s: 7160-0565-00, & 7160-0565-03,

Descriptions: Dock-Getac-T800

Certifications:

- EN 55022:2010 CISPR 22:2008 Class A
- EN 50498:2010
- EN 50581:2012

This device complies with Part 15 of the FCC Rules. Operation is subject to the following two conditions. (1) this device may not cause harmful interference, and (2) this device must accept any interference received, including interference that may cause undesired operation.



Gamber-Johnson LLC, 3001 Borham Ave.,
Stevens Point, WI, 54481, USA, 715-344-3482