



Very Well Connected™

# INSTALLATION INSTRUCTIONS

<b><u>Product</u></b> <b>7160-0792-XX</b> <b>RX10 CRADLE</b>	<b><u>Revision</u></b> REV. B	<b><u>Form</u></b> INST-696 <b>Printing Spec: PS-001</b>
--	----------------------------------	--

This instruction sheet is for the RX10 cradle only. For instructions on features, set-up, and operation of the RX10 computer, please refer to the manual provided by Getac with the computer.

This cradle is designed to be used with a variety of Gamber-Johnson mounting systems. Installation instructions for other Gamber-Johnson products are provided with each individual product.

This instruction sheet is for the following products:

### **For Vehicle Mounting Applications (1/4-20 Mounting Hardware):**

Item No. 7160-0792-00 No RF  
Item No. 7160-0792-03 Tri-RF

### **For Cart Mounting Applications (M4 Mounting Hardware):**

Item No. 7160-0792-04 No RF  
Item No. 7160-0792-05 Tri-RF

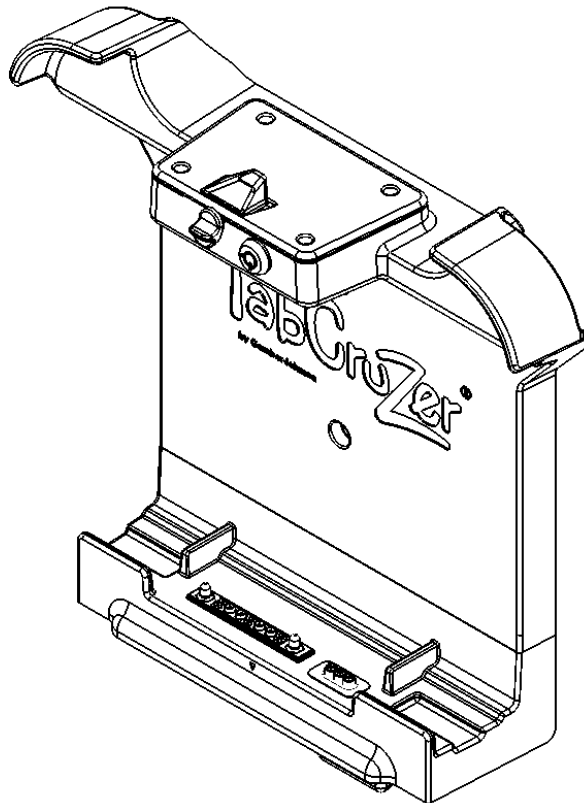

#### **Product Mounting Disclaimer**

Gamber-Johnson is not liable under any theory of contract or tort law for any loss, damage, personal injury, special, incidental or consequential damages for personal injury or other damage of any nature arising directly or indirectly as a result of the improper installation or use of its products in vehicle or any other application. In order to safely install and use Gamber-Johnson products full consideration of vehicle occupants, vehicle systems (i.e., the location of fuel lines, brakes lines, electrical, drive train or other systems), air-bags and other safety equipment is required. Gamber-Johnson specifically disclaims any responsibility for the improper use or installation of its products not consistent with the original vehicle manufactures specifications and recommendations, Gamber-Johnson product instruction sheets, or workmanship standards as endorsed through the Gamber-Johnson Certified Installer Program.

© Copyright 2015 Gamber-Johnson, LLC

If you need assistance or have questions, call Gamber-Johnson at 1-800-456-6868

# RX10 CRADLE FEATURE IDENTIFICATION

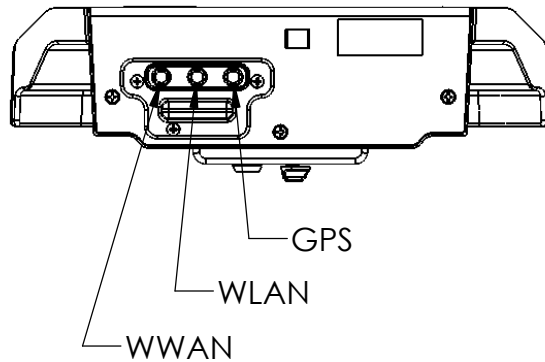
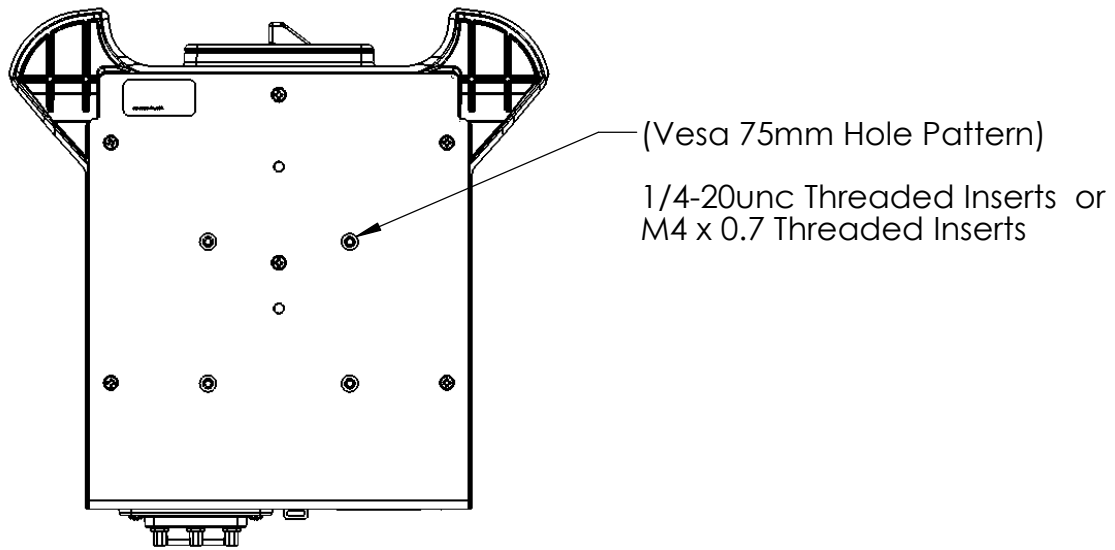
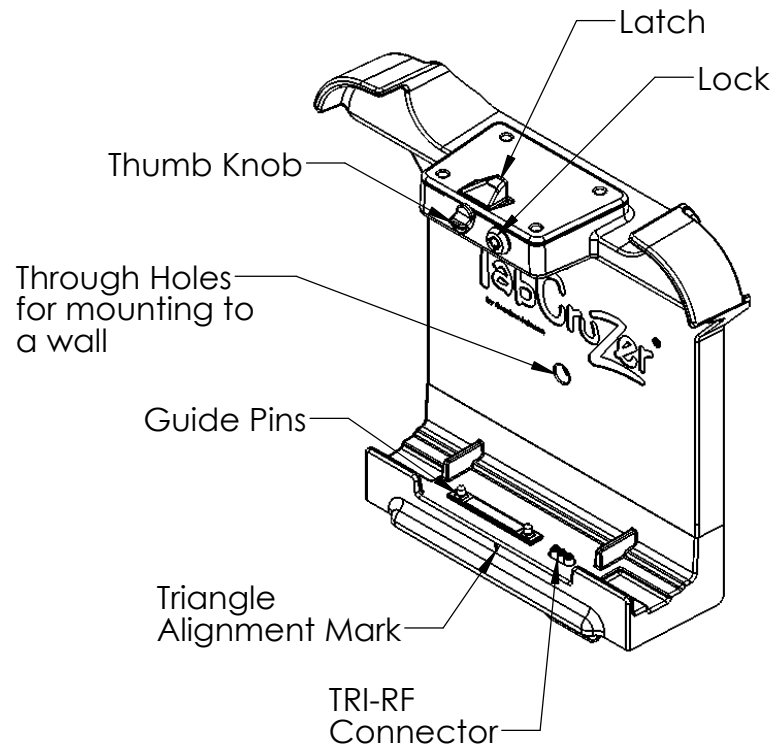

# INSERTING THE COMPUTER INTO THE CRADLE

## INSERTING THE COMPUTER

1. Insert the bottom of the computer into the cradle (the cradle and computer have triangle alignment guides to help with locating the computer correctly). See Figure 1.

Then rotate the top of the computer into the cradle until the latch housing comes through the computer handle opening and the latch springs upward to hold the unit in place. See Figure 2.

2. (Optional) The key lock can now be used for security purposes.



**Figure 1**



**Figure 2**

## REMOVING THE COMPUTER

1. Unlock if locked.

2. Push downward on the thumb knob and pull outward on the handle of the computer until it clears the latch housing. Lift the computer out of the dock. See Figure 3.



**Figure 3**