



# INSTALLATION INSTRUCTIONS

<b><u>Product</u></b> 7160-1942 ADAPTER - 75MM HOLES TO STUDS	<b><u>Revision</u></b> Rev A	<b><u>Form</u></b> INST-1157 <b>Printing Spec:</b> PS-001
---	---------------------------------	---

This instruction sheet is for the Gamber-Johnson 75mm hole to stud adapter plate. It is used when studs are needed for mounting applications and the dock or cradle has 1/4-20unc threaded inserts. Example = Gamber-Johnson docking stations for Getac computers used in the Material Handling industry when secondary scanner pockets or keyboard mounts are also being mounted. The adapter plate allows for 1 individual to install the entire assembly by placing the secondary mounts on the studs when assembling to the motion attachment.

### Mounting the adapter:

Attach the adapter plate to the docking station with the 1/4-20 x 1/2" long socket flat head machine screws found in hardware bag 7120-1156.

Attach the adapter plate to the motion attachment with the 1/4" flat washers and lock nuts provided in hardware bag 7120-1156.

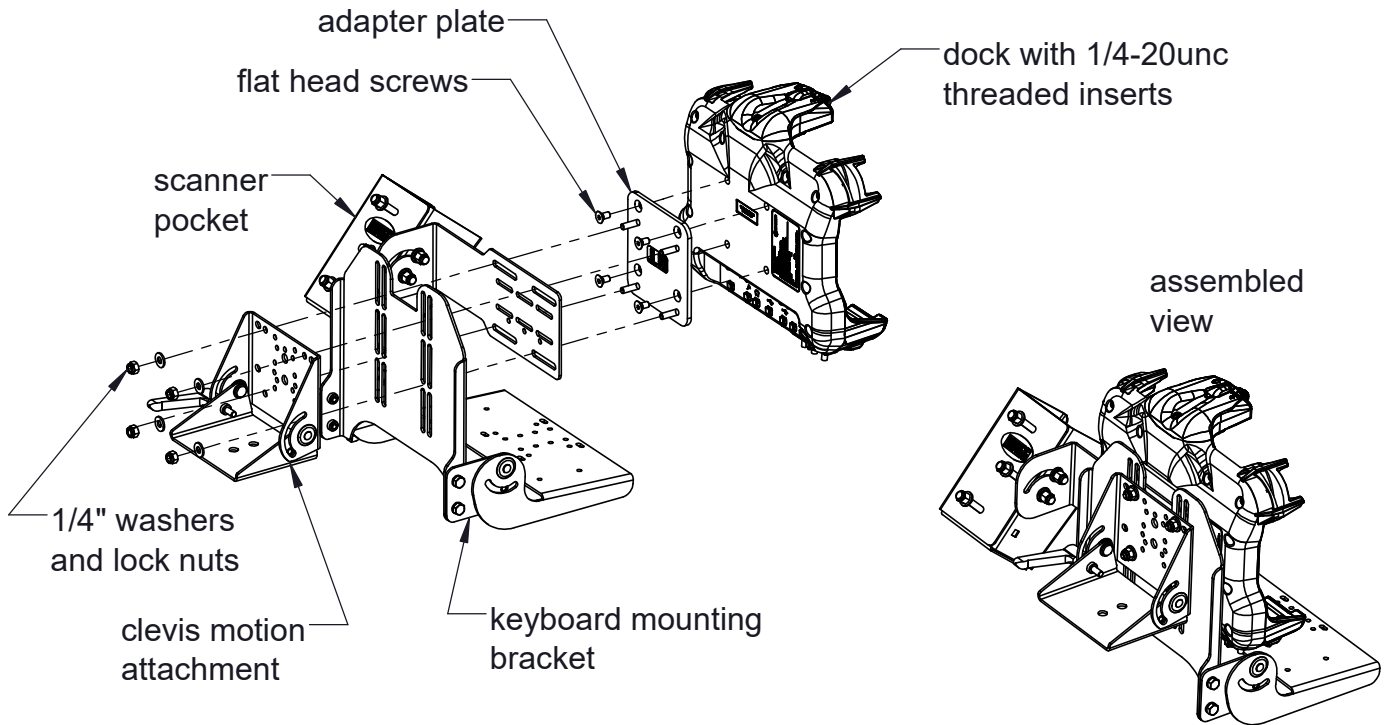

### Product Mounting Disclaimer

Gamber-Johnson is not liable under any theory of contract or tort law for any loss, damage, personal injury, special, incidental or consequential damages for personal injury or other damage of any nature arising directly or indirectly as a result of the improper installation or use of its products in vehicle or any other application. In order to safely install and use Gamber-Johnson products full consideration of vehicle occupants, vehicle systems (i.e., the location of fuel lines, brake lines, electrical, drive train or other systems), air-bags and other safety equipment is required. Gamber-Johnson specifically disclaims any responsibility for the improper use or installation of its products not consistent with original vehicle manufactures specifications and recommendations, Gamber-Johnson product instruction sheets, or workmanship standards as endorsed through the Gamber-Johnson Certified Installer Program.

© Copyright 2023 Gamber-Johnson, LLC

If you need assistance or have questions, call Gamber-Johnson at 1-800-456-6868